

BarrierGuard 800 Temporary & Permanent Steel Barrier

EN 1317



Despite the signalisation lights, cones and such, both road workers as well as road users are at risk during roadworks. With the help of a temporary barrier this workzone can be protected for the benefit of both workforce as well as road users. Used as a lane divider for traffic, BarrierGuard 800 allows for safe traffic separation. In the various counties there are different demands with respect to the containment-level and appearance. BarrierGuard 800 offers the most appropriate solution.

The BarrierGuard 800 is a successfully, according to EN 1317, tested barrier that combines various performance-levels into one basic product. The BarrierGuard 800 was tested N2, T3, H1 and H2 and fulfils these international demands. The so-called Step profile allows for a controlled crash behaviour with little damage to both the vehicle and the construction itself. The Step geometry is therefore often favoured by the various Road Administrations.



BarrierGuard 800 comes in pre-assembled 12m sections with a relative low weight. BarrierGuard 800 has a unique 'QuickMount' connector design without fasteners, allowing installation of up to 300 metres of barrier per hour. No fasteners are used that can get lost during stocking and installation. Combined with delivery of up to 216m per load BarrierGuard 800 provides a competitive installation cost. BarrierGuard 800 is quickly installed and removed and limits the disruptions to traffic, while reducing the overall carbon footprint.

The durability of the BG800 ensures that in the event of a typical vehicle collision, the damage to both is significantly reduced, with minimal debris, resulting in little or no requirement for repair. This ensures the ongoing safety of the workforce while allowing maximum lane usage on the busy road network. With its versatile design the BG800 allows for angle plates and angle sections to be used for tight radii. Connections to existing guardrails can be made with the help of standard connection pieces. BarrierGuard 800 is available with approved and CE marked crash cushions or end terminals.

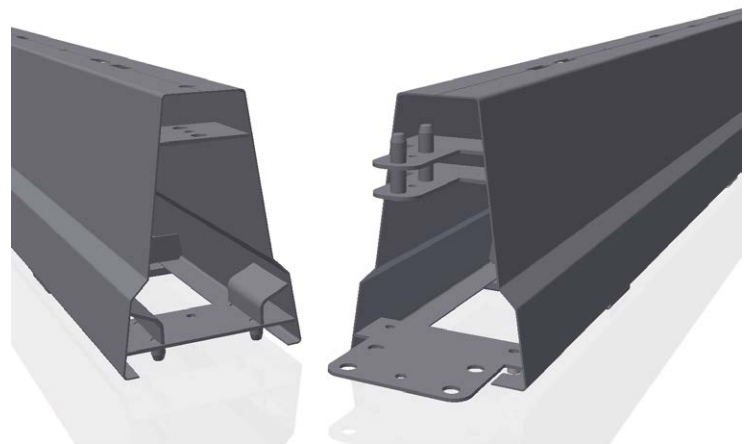
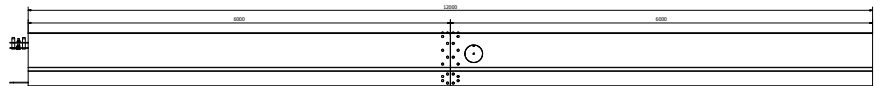
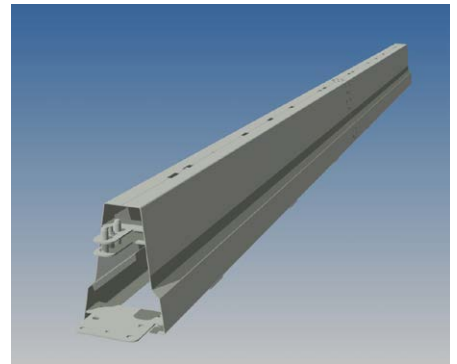
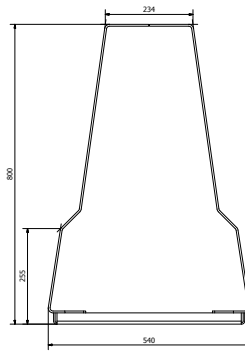

Advantages of the BarrierGuard800:

- + accepted by many Road Administrations
- + full-scale tested according EN 1317
- + T3, N2, H1, H2 performance level
- + relatively low weight
- + durable with low carbon footprint
- + QuickMount connectors
- + quick and easy installation
- + maintenance free
- + for workzones and lane division
- + crash cushions or end terminals

Product	Testnorm	Containment level	Containment	Type test	WW	Asi
BG800	EN 1317	Low angle containment	T3	TB41+TB21	W4	A
BG800	EN 1317	Normal containment	N2	TB32+TB11	W2	A
BG800	EN 1317	Higher containment	H1	TB42+TB11	W6	A
BG800	EN 1317	Higher containment	H2	TB51+TB11	W8	A
BG800	NCHRP-350/MASH	Higher containment	TL3	2.000kg Pick-up	-	-
BG800	NCHRP-350	Higher containment	TL4	2.000kg Pick-up	-	-

For more information or tailored advise on the application of road restraint systems please contact Laura Metaal Road Safety on: +31 (0) 45 546 88 88 or see www.laurametaal.nl. It will be our pleasure to help you.